

P O L A R S E R I E S



Henkelman's Polar series offer a complete range of single and double chamber equipment for MAP and vacuum packaging. All Polar models are completely made of stainless steel. With a flat work plate and extensive program and option possibilities. With removable silicon holders and the seal mechanism mounted in the lid. User friendly, low maintenance and fully HACCP compatible. Henkelman's Polar series are especially suitable for the industrial packaging of both food and non-food.



Henkelman BV
Postbox 2117
5202 CC 's-Hertogenbosch
T + 31 73 621 36 71
F + 31 73 622 13 18
info@henkelman.com

WWW.HENKELMAN.COM

POLAR 2-95

WITH AUTOMATIC LID

NEW



Option
2 x 850 mm seal

Option
3 x 1100 mm seal

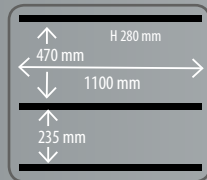
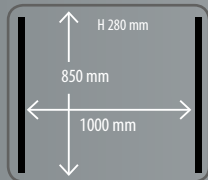
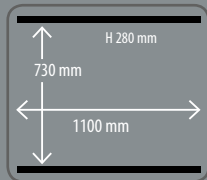

Pump capacity 300 m³/h
Machine cycle 15-40 sec
Dimensions 1215 x 2420 x 1130 mm
Weight 767 kg
Voltage 400V-3-50Hz (other voltages available)
Power 7.0 - 9.0 kW

SPECIFICATIONS

GENERAL DESCRIPTION

Polar 2-95 is a double chamber vacuum packaging machine with an optional automatic lid. An interesting new feature is the foot pedal to semi-automatically operate the lid. Perfect for the industrial packaging of both food and non-food products. The automatic lid, available on new machines Polar 2-85 and Polar 2-95, offers numerous ergonomic advantages and a guaranteed output.

PACKAGING FUNCTIONS

Vacuum Optimal final vacuum 99.99% (0.1 Mbar)
Gas flush* Injecting food gas protects products and extends shelf life
Soft air Controlled ventilation for protection of product and packaging
Automatic lid* Including foot pedal for semi-automatic operation

SEAL SYSTEMS

Double seal 2 x 3.5 mm convex seal wire for optimal moisture elimination
Cut-off seal* 3.5 mm convex seal wire + 1.1 mm round cut wire
1-2 Cut-off seal* 3.5 mm convex seal wire + 1.1 mm round cut wire (independent time setting)
Wide seal* 8.0 mm flat seal wire
Bi-active seal* Upper and lower seal bars with 5.0 mm flat seal wire (thick and aluminium vacuum bags)

OPERATIONAL CONTROL

Digital control Time control, automatic programming, 10 default programs
Sensor control* Set percentage pressure for vacuum and gas functions, automatic programming, 10 default programs, vacuum plus time
Liquid control* Set percentage pressure for vacuum and detect boiling point of liquids
Advanced Control System* Set percentage pressure or mbar/hPa for vacuum and gas function, 20 default alphanumeric programs, vacuum plus time, sequential vacuum, Secured Operator Access, HACCP track and trace function, LCD full color screen, PC interface, compatible with label printer, Marinating function

SUPPORT CONTROL

STOP button for interruption
Digital maintenance program, Sensor for cycle interruption in case of entrapment, Operating hours counter, Service indicator programs, Sleeper function

ACCESSORIES

Service kit for standard maintenance*
Insert plates for adjusting vacuum chamber height
Filler plates for a faster vacuum and a decrease of gas*

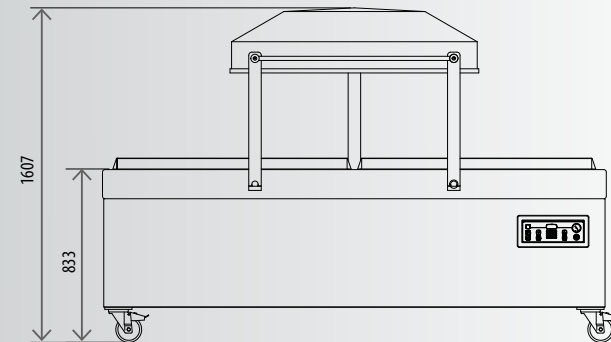
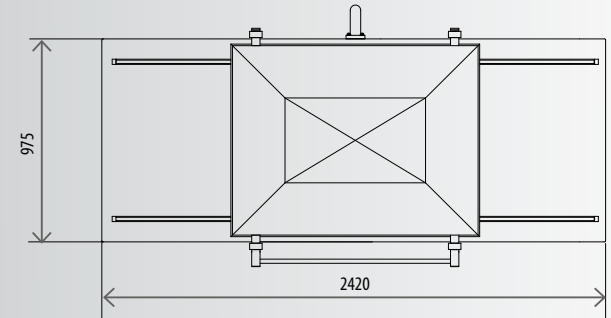

Foot pedal for semi-automatic operation

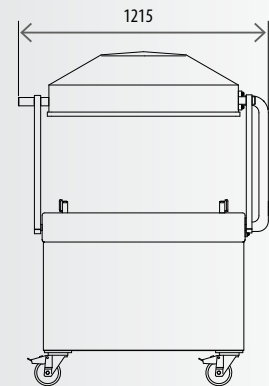

STOP button for interruption at any time

*Option

Dimensions of the seal bar configurations listed refer to the space available between the seal bars
Textual and printing errors reserved